

**UNIVERSITY COLLEGE TATI (UC TATI)****FINAL EXAMINATION QUESTION BOOKLET**

COURSE CODE	: DND 3043
COURSE	: EDDY CURRENT TESTING I
SEMESTER/SESSION	: 2-2022/2023
DURATION	: 3 HOURS

Instructions:

1. This booklet contains **4** questions. Answer **all** questions.
2. All answers should be written in answer booklet.
3. Write legibly and draw sketches wherever required.
4. If in doubt, raise your hands and ask the invigilator.

DO NOT OPEN THIS BOOKLET UNTIL YOU ARE TOLD TO DO SO

THIS BOOKLET CONTAINS 8 PRINTED PAGES INCLUDING COVER PAGE

EDDY CURRENT TESTING I (DND 3043)

QUESTION 1

- a) Refer to Figure 1, calculate the followings:

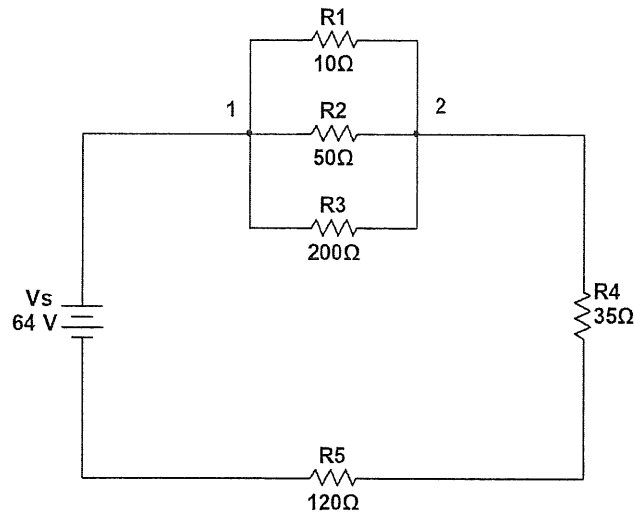

Figure 1

- i. The total resistance, R of the circuit. (2 marks)
 - ii. The current, I through the circuit. (2 marks)
 - iii. The voltage, V across R_4 . (2 marks)
 - iv. The voltage, V across R_5 . (2 marks)
 - v. The voltage, V across point 1 to point 2. (2 marks)
 - vi. The current, I through R_2 . (2 marks)
 - vii. The total power, P used in the circuit. (2 marks)
- b) A simple circuit requires three things which are a source of electrical potential difference or voltage, a conductive path which would allow for the movement of charges and an electrical resistance (resistor).
- i. Define Ohm's Law. (2 marks)
 - ii. State the unit for Voltage, Power, Resistance and Inductance. (2 marks)
 - iii. Describe Faraday's Law. (4 marks)
 - iv. Explain **three (3)** factors affecting Faraday's Law. (3 marks)

EDDY CURRENT TESTING I (DND 3043)

QUESTION 2

- a) Figure 2 shows the impedance, Z vector diagram of the electrical circuit with the resistance, R is 70 Ohms, inductive reactance, X_L is 50 Ohms and capacitive reactance X_C is 3 Ohms.

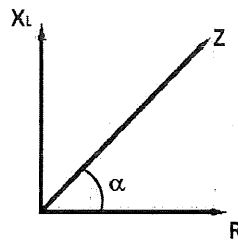

Figure 2

- Define impedance, Z . (2 marks)
 - State the unit for impedance, Z . (1 mark)
 - Calculate the resultant impedance, Z . (2 marks)
 - Calculate the phase angle, α . (2 marks)
 - Sketch a phase represents current and voltage of AC reach a maximum, minimum and zero value at the same time. (2 marks)
- b) Figure 3 shows an alternating current (AC) circuit operating at frequency of 125 kHz.

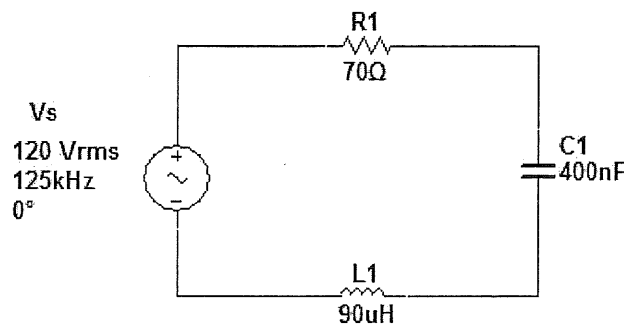

Figure 3

- If the inductor, L_1 and capacitor, R_1 are removed from the circuit of figure 3, explain what happen to the phase of current and voltage. (2 marks)

EDDY CURRENT TESTING I (DND 3043)

- ii. Sketch the answer for question i. that showing the phase of current and voltage. (3 marks)
- iii. Calculate the inductive reactance of an inductor, L1. (2 marks)
- iv. Calculate the capacitive reactance of a capacitor, C1. (2 marks)
- v. Calculate the impedance, Z. (2 marks)
- vi. Calculate the phase angle, α . (2 marks)
- vii. Draw the vector diagram that consists of the impedance, inductive reactance, capacitive reactance and resistance for the circuit of Figure 3. (3 marks)

EDDY CURRENT TESTING I (DND 3043)

QUESTION 3

- a) Eddy Current Testing is based on the same principles of electricity and magnetism that are used to generate the electrical power used to light our homes and other electrical devices.
- Define permeability. (2 marks)
 - Describe the principles of Eddy Current Testing based on electromagnetic principle. (5 marks)
 - Sketch the principle of Eddy Current Testing based on **question 3 a) ii**. (5 marks)
 - Calculate the standard depth of penetration, δ (cm) for Aluminum by using formula and data in Table 1. (3 marks)

Table 1

Formula	$\delta = \frac{1}{\sqrt{\pi f \mu \sigma}}$
Frequency, f	100 kHz
Conductivity, σ	37 %IACS
Permeability, μ	$4\pi \times 10^{-9}$ H/cm

- b) If a current is passed through a wire, a weak magnetic field is produced. The strength of magnetic field depends on value of current passed through.
- List **three (3)** ways to increase the induced electromagnetic force. (3 marks)
 - Illustrate a magnetic field pattern around a solenoid. (3 marks)
- c) An approximation of small, multilayer, air coil inductance has 0.20-inch means radius of coil, 0.18-inch length of coil and 0.15-inch thickness of coil. Calculate the inductance of a coil, L that has the total number of turns is 70. (4 marks)

EDDY CURRENT TESTING I (DND 3043)

QUESTION 4

- a) There are four fundamental properties of materials that affect the Eddy currents induced in the test material. Variation of these fundamental properties cause change in the impedance of test circuit.
- Define conductivity. (2 marks)
 - List **four (4)** fundamental properties of materials that affect the Eddy currents induced in the test material. (4 marks)
 - Describe **two (2)** factors affecting conductivity. (4 marks)
 - Explain what happen to the depth of penetration and surface intensity of Eddy Current happen if the operating frequency is decreased. (2 marks)
- b) Figure 4 shows the internal probe of Eddy current inside the tube of heat exchanger. d_i is the probe diameter and D_o is the tube diameter to be inspected. Given d_i is 10 mm and D_o is 20 mm. Calculate the followings:

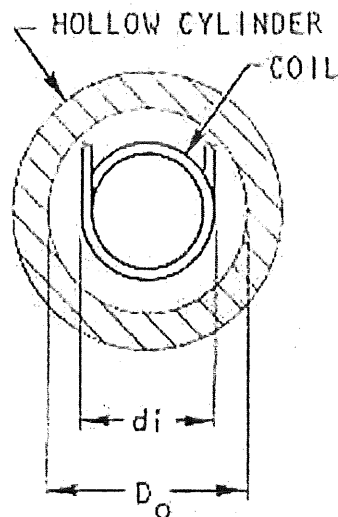

Figure 4

- The fill factor of the internal probe over the tube. (2 marks)

EDDY CURRENT TESTING I (DND 3043)

- ii. The best probe diameter to ensure the fill factor of about 70% of the tube.
(3 marks)
- c) Lift off and fill factor are essentially the same thing. One is applied to surface coils and the other to encircling and internal coils.
- i. Define lift off. (2 marks)
- ii. Illustrate the comparison signal for the measurement of coating thickness on carbon steel using absolute probe and D50 calibration block.
(4 marks)
- iii. Illustrate the deflection of signal displayed on Eddy current set for positive and negative movement of the probe along the 1 mm slot on D50 calibration block. (2 marks)

-----End of question-----

EDDY CURRENT TESTING I (DND 3043)

List of Formula

1. *Inductive Reactance, $X_L = 2\pi fL$*
2. *Capacitive Reactance, $X_C = \frac{1}{2\pi fL}$*
3. *Inductance, $L = \frac{[0.8(rN)^2]}{[6r + 9c + 10b]}$*